

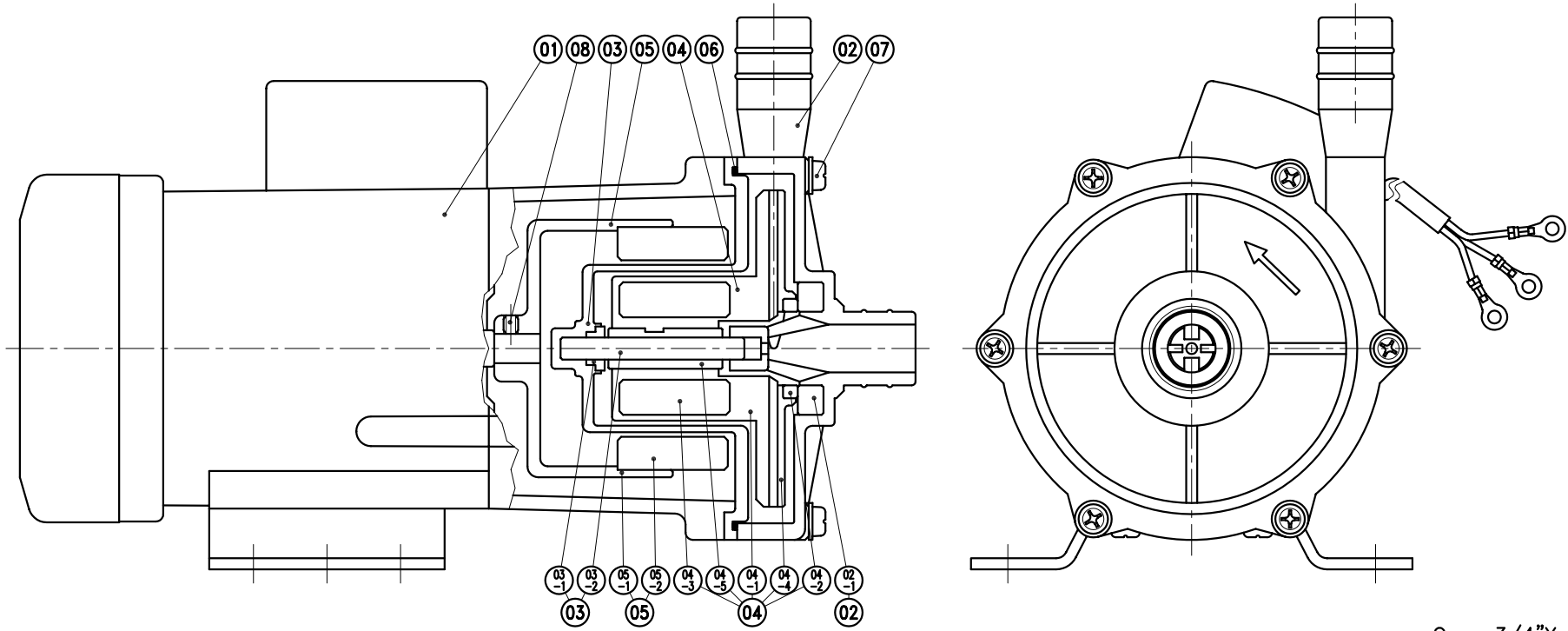

03-2	SPINDLE	1	CERAMIC	∅6X50	P2339291	04-5	BEARING	1	CERAMIC	∅11X31	P2469482	08	SET SCREW	2	S435	M4X5	P9119420	
03-1	REAR THRUST PAD	1	PPS	∅12X∅9X5	P2329477	04-4	IMPELLER COVER	1	PPG	∅90X6	A2451316	07	SCREW,CROSS RECESS HEAD w/t P.W.(∅10X∅5.3Xt1)	6	SUS304	M5X28	A9111101	
03	REAR CASING	1	PPG	∅107X53.5	A2301304	04-3	INNER MAGNET	1	FERRITE	∅36X∅17X30	P2449487	06	O. RING	1	FKM	∅94.5X∅2	S95	
02-1	FRONT THRUST PAD	1	CERAMIC	∅36X∅20X6.5	A2221276	04-2	MOUTH RING	1	RULON	∅27X4.5	P2421462	05-2	OUTER MAGNET	1	FERRITE	∅66X30	P2529488	
02	FRONT CASING	1	PPG	∅107X48.5	A2211303	04-1	IMPELLER VANE	1	PPG	∅90X46	A2411306	05-1	MAGNET HOUSING	1	ADC-12	∅70X48.5	P2519003	
01	MOTOR	100~120V,200~240V , 65W,1∅,2P					04	IMPELLER ASS'Y	1	PPG	∅86X51.5	A2401314	05	OUTER DRIVE RING	1		∅70X63.5	P2509196
NO	PART NAME	Q'TY	MATERIAL	NOTE	DWG. NO.	NO	PART NAME	Q'TY	MATERIAL	NOTE	DWG. NO.	NO	PART NAME	Q'TY	MATERIAL	NOTE	DWG. NO.	



G : 3/4"X 3/4"
NPT : 3/4"X 3/4"

APPROVED		MDL, NAME	NH-100PX-ZZ		
UNIT	MM	CHECK	07 16 02	DWG, NAME	CONSTRUCTION DRAWING
SCALE	4:5	DESIGN	07 31 01	DWG, NO.	B2101829
EDITION	2	DR.BY	07 16 02 BECKY		A3
TPW HONG YUAN		 PAN WORLD CO.,LTD. パンワールド株式会社			